

客戶名： _____

規格書

產品型號 _____ 2X3X4白-藍光

規格書號碼 _____

確認

鈺光科技股份有限公司

E-light Technology inc.

地址：**231**台北縣新店市文化路**60**號**1**樓

ADDRESS:1/F No.60, Wunhua Rd., Sindian City,
Taipei, 231 R.O.C.

電話 (TEL)：+886-2-29107483

傳真 (FAX)：+886-2-29114375

產品型號	2X3X4白-藍光	制訂單位	工程部	編制	楊波
規格書號碼		制訂時間	2007.11.03	審核	

● COMMODITY: 2X3X4

● ELECTRICAL AND OPTICAL CHARACTERISTICS (Ta=25°C)

Chip		Lens Appearance	Absolute Maximum Rating			Electro-optical Data(At 20mA)		Viewing Angle
Emitted Color	Peak Wave Length λ_P (nm)		$\Delta\lambda$ (nm)	Pd (mW)	If (mA)	Vf(V)	Iv Typ(mcd) Min Max	2 θ 1/2 (deg)
Super Blue	460~475	Blue Diffused	10	100	30	3.0~3.6	50 500	90 ± 5

Remark : Viewing angle is the Off-axis angle at which the luminous intensity is half the axial luminous intensity.

● PACKAGE DIMENSIONS

Type :

Unit : mm

Tolerance : +/- 0.1

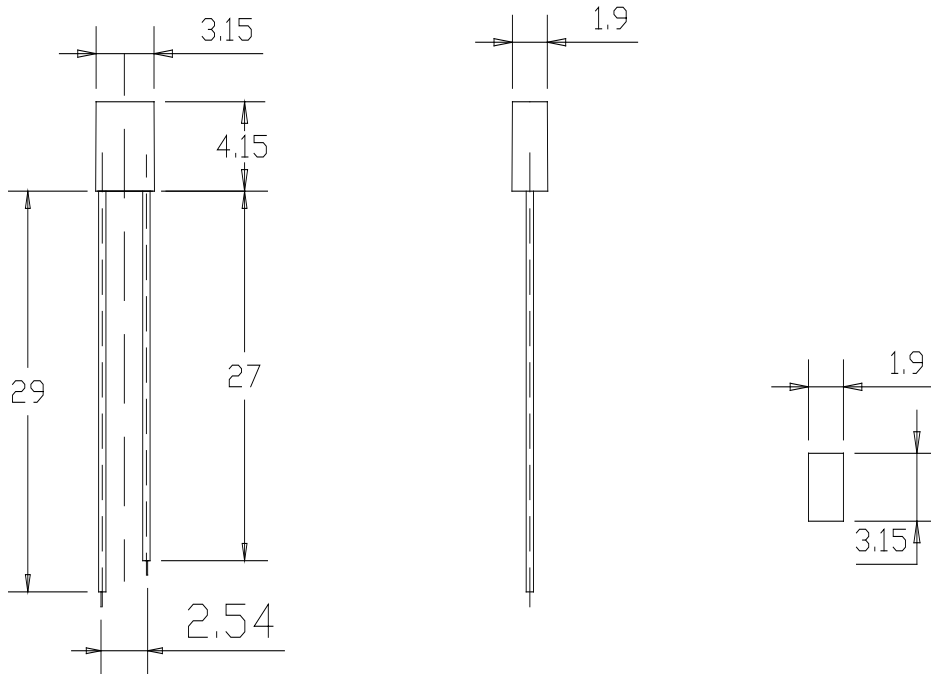

NOTES:

- 1.All dimensions are in millimeters.
- 2.Tolerance is +0.25mm(0.01) unless otherwise specified
- 3.Lead spacing is measured where the leads emerge from the package.
- 4.Specifications are subject to change without notice.

產品型號	2X3X4白-藍光	制訂單位	工程部	編制	楊波
規格書號碼		制訂時間	2007.11.03	審核	

Optoelectronic Characteristics at Ta=25°C.

■ Chip:

Parameter	Symbol	Condition	Value	Unit
Forward Voltage	V_F	$I_F = 20 \text{ mA}$	3.0~3.6	V
CIE Value (X, Y)*	A	$I_F = 20 \text{ mA}$	460~465	nm
	B		465~470	
	C		470~475	
Luminous Intensity*	I_o	$I_F = 20 \text{ mA}$	50~500	mcd
Operating Temperature	T_{OPR}		-40 ~ +85	°C
Storage Temperature	T_C		-40 ~ +85	°C
Leakage current	I_r	-5V	≤5	uA

* LED reading.

* Customer can select which CIE range(A, B or C) they need.

* One delivery will include four different ranks of the luminous intensity depend on customer request.

Absolute Maximum Ratings.

	Maximum Value	Unit
DC forward current per chip	20	mA
Peak pulse current; (1/10 duty cycle, Pulse width =0.1msec)	100	mA
Reverse voltage.	5	V
LED junction temperature.	125	°C
Operating temperature.	-40 ~ +85	°C
Storage temperature.	-40 ~ +85	°C
Power dissipation (at room temperature)	100	mW

產品型號	2X3X4白-藍光	制訂單位	工程部	編制	楊波
規格書號碼		制訂時間	2007.11.03	審核	

Group Definition of wavelength and brightness, forward voltage (@20mA)

A Type

CIE	Brightness @20mA	No	Vf@ 20mA
460~465	50 ~ 100mcd 100~200mcd 200~300mcd 300~400mcd 400~500mcd	1	3.0-3.1
		2	3.1-3.2
		3	3.2-3.3
		4	3.3-3.4
		5	3.4-3.5
		6	3.5-3.6

B Type

CIE	Brightness @20mA	No	Vf@ 20mA
465~470	50 ~ 100mcd 100~200mcd 200~300mcd 300~400mcd 400~500mcd	1	3.0-3.1
		2	3.1-3.2
		3	3.2-3.3
		4	3.3-3.4
		5	3.4-3.5
		6	3.5-3.6

C Type

CIE	Brightness @20mA	No	Vf@ 20mA
470~475	50 ~ 100mcd 100~200mcd 200~300mcd 300~400mcd 400~500mcd	1	3.0-3.1
		2	3.1-3.2
		3	3.2-3.3
		4	3.3-3.4
		5	3.4-3.5
		6	3.5-3.6

* One delivery would be included 54 different ranks of the luminous intensity ,
wavelength and Vf depend on customer request.

* The quantity ratio of the different intensity and wavelength ranks in one delivery is decided by YG.

* The reel of LED shows the number of definition of LEDs on reel label.

產品型號	2X3X4白-藍光	制訂單位	工程部	編制	楊波
規格書號碼		制訂時間	2007.11.03	審核	

Optical and electrical characteristics

Relative luminous intensity vs. forward current.

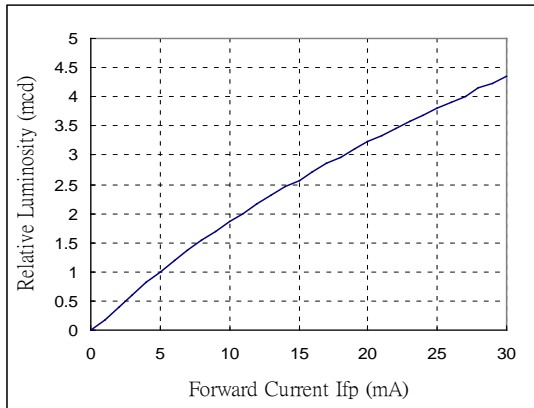

Forward current vs. forward voltage.

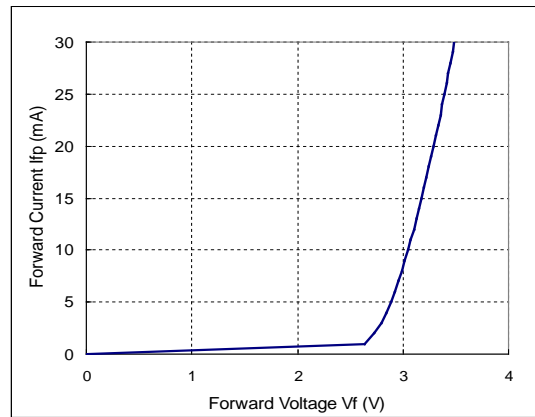

Allowable Forward Current vs. Ambient Temperature.

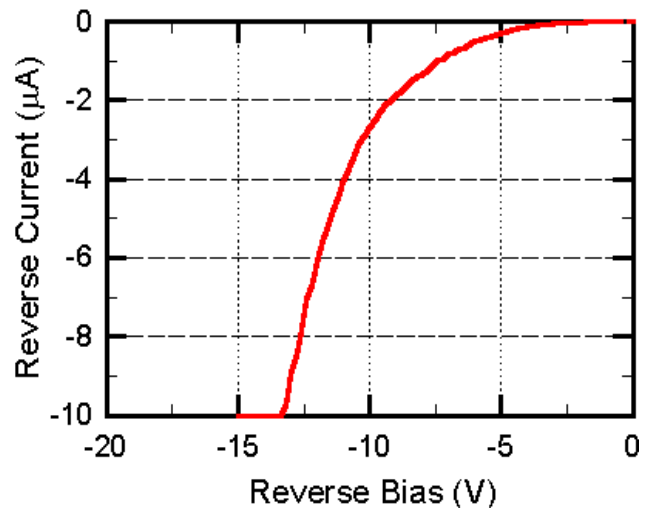
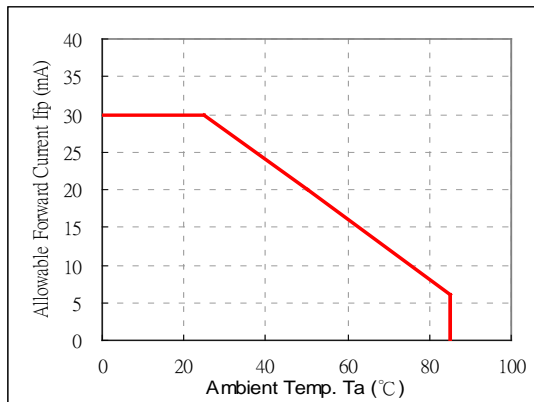

Recommended Soldering Temperature - Time Profile (Reflow Soldering)

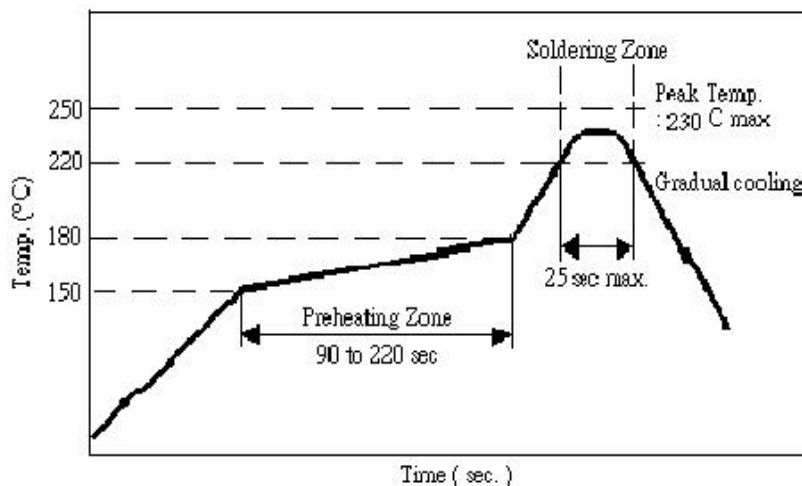

鉅光科技股份有限公司

E-light Technology inc.

產品型號	2X3X4白-藍光	制訂單位	工程部	編制	楊波
規格書號碼		制訂時間	2007.11.03	審核	

Reliability Test :

NO	Test Item	Test Conditions	Time	Results (Failure/ Sample Size)
1.	Thermal Cycle Test (168 cycle)	H : +75°C 30min ~ L : -35°C 30min	168Hrs	0/20
2	Thermal Shock Test (84 cycle, Rate=5min)	-40 °C(Holding 120 min) --> 85°C(Holding 120 min) 15 cycles, rate = 5 min	168Hrs	0/20
3.	High Temp. Storage Test	85°C, 120 Hr	168Hrs	0/20
4.	Low Temp. Storage Test	-25°C, 120 Hr	168Hrs	0/20
5	High Temp. High Humidity Test	80°C, 85% RH, 168 Hr M.S. Level 3M.S. Level 3	168Hrs	0/20
6	Press Cook Test	T=121°C, P=2atm, H=100%RH	168Hrs	0/20
7	Operating Life Test	If=20mA, 25°C	500Hrs	0/20
8	Soldering Heat Test	260+/-10°C, 10 sec	2 Times	20
9	ESD Test	HBM Class 1		10
10	Drop Test	152 cm, 12 times		20

Conclusions:

The reliability tests were designed to evaluate both package integrity as well as workability of product performance over time.

All samples have done well by completed test requirement and passed all the qualification criteria with zero failure.

From design standpoint, the package is robust enough to meet its datasheet conditions.

Based on the good result shows on the above test, this product is qualified and released for market.